

TMC-401 Datasheet



Version: 1.0
Date: 16 March 2007



Trinamic Motion Control GmbH & Co KG
Sternstraße 67
D - 20 357 Hamburg, Germany
<http://www.trinamic.com>

Contents

1	Features.....	3
2	Life support policy.....	4
3	Technical Data.....	5
3.1	Clock.....	5
3.2	Power supply.....	5
3.3	Pin assignments.....	5
4	Operational Ratings.....	6
5	Functional Description.....	7
5.1	Overview of In- and Outputs.....	7
5.2	Application with a TMC239 or TMC249 driver with SPI.....	8
5.3	Inputs.....	8
5.3.1	Step- / Direction signal.....	8
5.3.2	Setting of microstep resolution.....	9
5.3.3	Automatic Power down.....	9
5.3.4	Mixed Decay.....	9
5.3.5	Disable.....	10
5.3.6	Reset.....	10
5.4	Outputs.....	10
5.4.1	Overtemperature pre-warning.....	10
5.4.2	StallGuard.....	10
6	Package information.....	11
7	Documentation Revision.....	12
8	References.....	12

List of Figures

Figure 5.1:	Main parts of the TMC401.....	7
Figure 5.2:	Overview of In- and Outputs.....	7
Figure 5.3:	Application with a TMC239 or TMC249 driver with SPI.....	8
Figure 5.4:	Step / Direction signal timing.....	8
Figure 5.5:	Power down feature.....	9
Figure 5.6:	Different Chopper Cycles with Fast and Slow Decay.....	10
Figure 6.1:	Package Outline.....	11

List of Tables

Table 1.1:	Order codes.....	3
Table 3.1:	Pin assignments.....	5
Table 4.1:	Operational Ratings.....	6
Table 5.1:	Mircostep resolution setting.....	9
Table 6.1:	Package Dimensions.....	11

1 Features

The TMC401 converts step/direction signals into SPI datagrams that can be used to drive a TMC236, TMC239, TMC246 or TMC249 stepper motor driver chip directly. It provides five different microstep resolutions (from 1/32 to 1/2) as well as two full step resolution modes. The StallGuard™ bits of a TMC246 or TMC249 motor driver are output on three pins, in order to allow an easy usage of the StallGuard feature. Also the overtemperature pre-warning bit is output on one extra pin (and can be used to shut off the driver when there is an overtemperature pre-warning condition).

The TMC401 also provides a feature that reduces the motor current to 25% when there have not been any step pulses for at least one second. This features can be enabled or disabled. Mixed Decay can also be enabled or disabled using a dedicated pin.

Applications

- Step-/ Direction signal to SPI datagram converter
- Perfect for use with TMC236, TMC239, TMC46 or TMC249 stepper motor driver chip
- Interprets driver feedback via SPI like StallGuard values and overtemperature pre-warning

Electrical data

- +5V power supply
- TTL levels on all in- and outputs

Features

- Up to 32 times microstepping
- Two different full step resolution modes
- Output of StallGuard™ values for sensorless motor stall detection
- Overtemperature pre-warning
- Mixed Decay can be enabled or disabled for best motor performance
- Optional intelligent current management at step pulse pauses

Other

- RoHS compliant
- 32 pin TQFP package

Order code	Description
TMC401-PI	Step- /Direction to SPI converter for use with TMC236, TMC239, TMC246 or TMC249 stepper motor driver chips in 32pin TQFP package

Table 1.1: Order codes

2 Life support policy

TRINAMIC Motion Control GmbH & Co. KG does not authorize or warrant any of its products for use in life support systems, without the specific written consent of TRINAMIC Motion Control GmbH & Co. KG.

Life support systems are equipment intended to support or sustain life, and whose failure to perform, when properly used in accordance with instructions provided, can be reasonably expected to result in personal injury or death.

© TRINAMIC Motion Control GmbH & Co. KG 2007

Information given in this data sheet is believed to be accurate and reliable. However no responsibility is assumed for the consequences of its use nor for any infringement of patents or other rights of third parties, which may result from its use.

Specifications subject to change without notice.

3 Technical Data

3.1 Clock

The device runs on an internal 8MHz RC-oscillator. So an external clock is not needed.

3.2 Power supply

The power supply should be in the range of +5V \pm 5%. Use all +5V and GND pins in parallel to lower the contact resistance.

3.3 Pin assignments

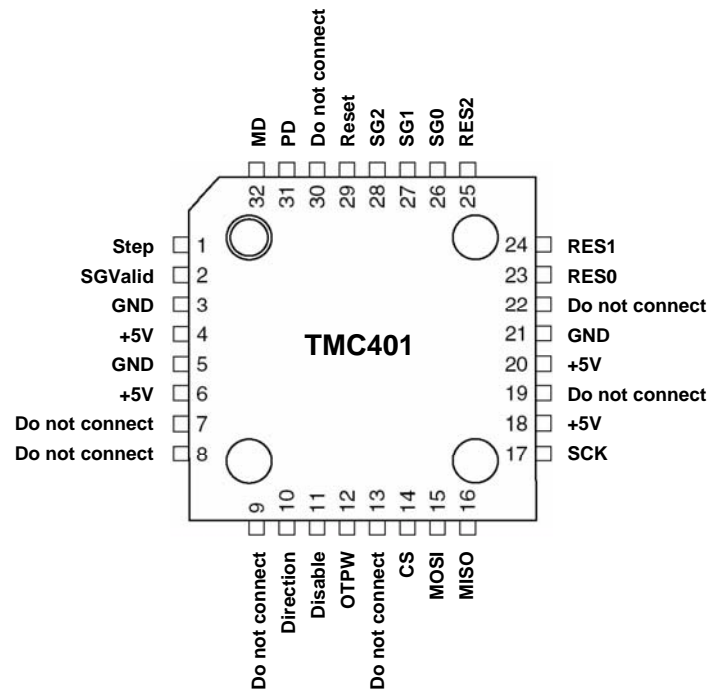

Pin Number	Name	Dir	Explanation
1	Step	In	Step pulse input; a low-to-high transition triggers one microstep
2	SGValid	Out	Output, low pulse (4 μ S) when SGo..SG2 outputs are valid
3	GND	In	Ground
4	+5V	In	+5V power supply
5	GND	In	Ground
6	+5V	In	+5V power supply
7 - 9	Do not connect		
10	Direction	In	Direction signal input. Sampled with every step pulse.
11	Disable	In	GND: SPI pins tristated, +5V and open: SPI communication enabled
12	OTPW	Out	Overtemperature Pre-Warning output: High when OTPW bit set
13	Do not connect		
14	CS	Out	SPI Chip select output (connect to CSN of the TMC23x/24x)
15	MOSI	Out	SPI Data Output (connect to SDI of the TMC23x/24x)
16	MISO	In	SPI Data Input (connect to SDO of the TMC23x/24x)
17	SCK	Out	SPI Clock Output (connect to SCK of the TMC23x/24x)
18	+5V	In	+5V power supply
19	Do not connect		
20	+5V	In	+5V power supply
21	GND	In	Ground
22	Do not connect		
23	RES0	In	Microstep resolution selection
24	RES1	In	Microstep resolution selection
25	RES2	In	Microstep resolution selection
26	SGo	Out	StallGuard output (load detection bit 0)
27	SG1	Out	StallGuard output (load detection bit 1)
28	SG2	Out	StallGuard output (load detection bit 2)
29	Reset	In	Reset input, can be pulled low to reset the device; normally leave open or connect to +5V via pull-up resistor (device has automatic power-on reset)
30	Do not connect		
31	PD	In	Automatic power down active when low
32	MD	In	Mixed decay active when low

Table 3.1: Pin assignments

4 Operational Ratings

The operational ratings show the intended / the characteristic range for the values and should be used as design values. In no case shall the maximum values be exceeded.

Symbol	Parameter	Min	Typ	Max	Unit
V_{CC}	Power supply voltage for operation	4.8	5	5.2	V
I_{CC}	Power supply current			15	mA
f_{CLOCK}	Internal 8MHz RC-oscillator		8		MHz
V_{IL}	Input low voltage	-0.5		$0.2 V_{CC}$	V
V_{IH}	Input high voltage	$0.6 V_{CC}$		$V_{CC} + 0.5$	V
V_{ILR}	Input low voltage on reset pin	-0.5		$0.2 V_{CC}$	V
V_{IHR}	Input high voltage on reset pin	$0.9 V_{CC}$		$V_{CC} + 0.5$	V
V_{OL}	Output low voltage (at $I_{OL}=20mA$)			0.7	V
V_{OH}	Output high voltage (at $I_{OL}=20mA$)	4.2			V
I_{IL}	Input leakage (current I/O, pin low)			1	μA
I_{IH}	Input leakage (current I/O, pin high)			1	μA
R_{RST}	Reset pin pull-up resistor	30		80	$k\Omega$
R_{PU}	I/O pin pull-up resistor	20		50	$k\Omega$
f_{STEP}	Step frequency			245	kHz
t_{SPulse}	Step pulse length	0.125			μs
t_{S2D}	Direction hold time	2.0			μs
T_{D2S}	Direction to step delay	0			μs
T_{MAX}	Absolute maximum Temperature	-55		+125	$^{\circ}C$
T_{OP}	Operating Temperature	-40		+85	$^{\circ}C$

Table 4.1: Operational Ratings

5 Functional Description

The main parts of the TMC401 communication interface chip are shown in Figure 5.1 The chip converts a Step- /Direction signal into a SPI datagram with full support of the additional functions provided by Trinamics driver family. A power down feature at inactivity, mixed decay and microstep resolution can be controlled and the drivers feedback StallGuard and temperature pre warning are supported.

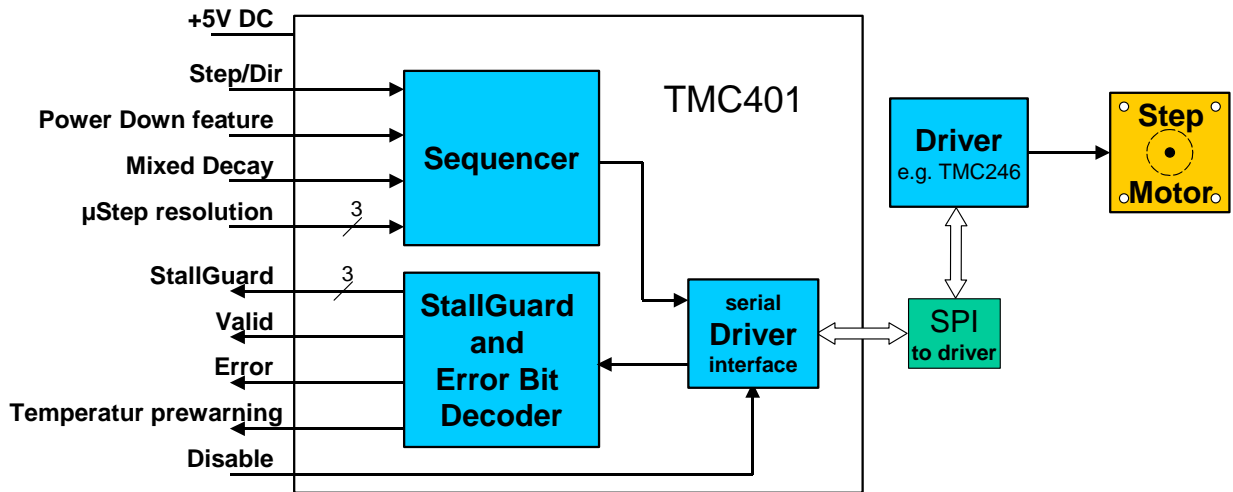

Figure 5.1: Main parts of the TMC401

5.1 Overview of In- and Outputs

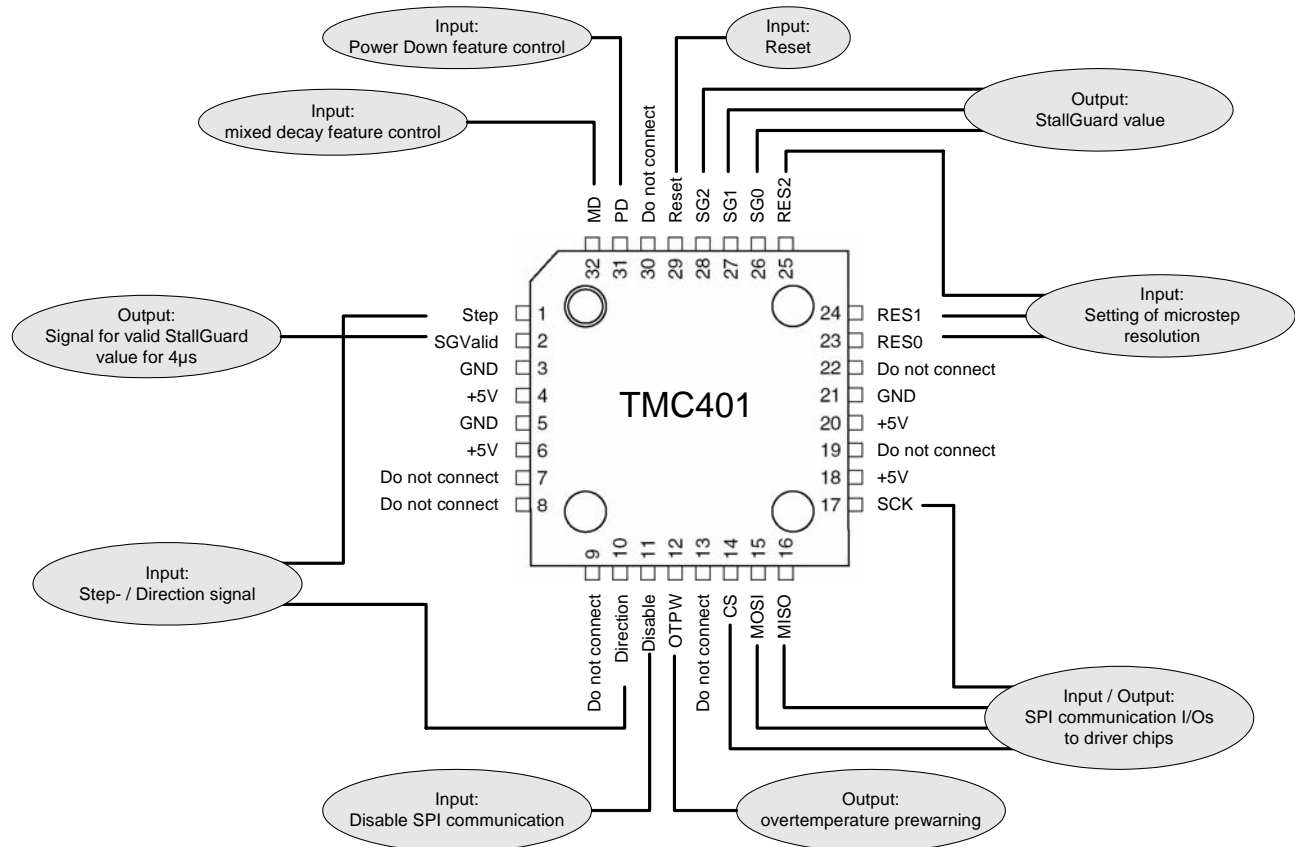

Figure 5.2: Overview of In- and Outputs

5.2 Application with a TMC239 or TMC249 driver with SPI

Since the SPI datagram is completely calculated internally the only effort to be taken is to connect the SPI pins of the TMC401 to the TMC23x or TMC24x SPI interface pins.

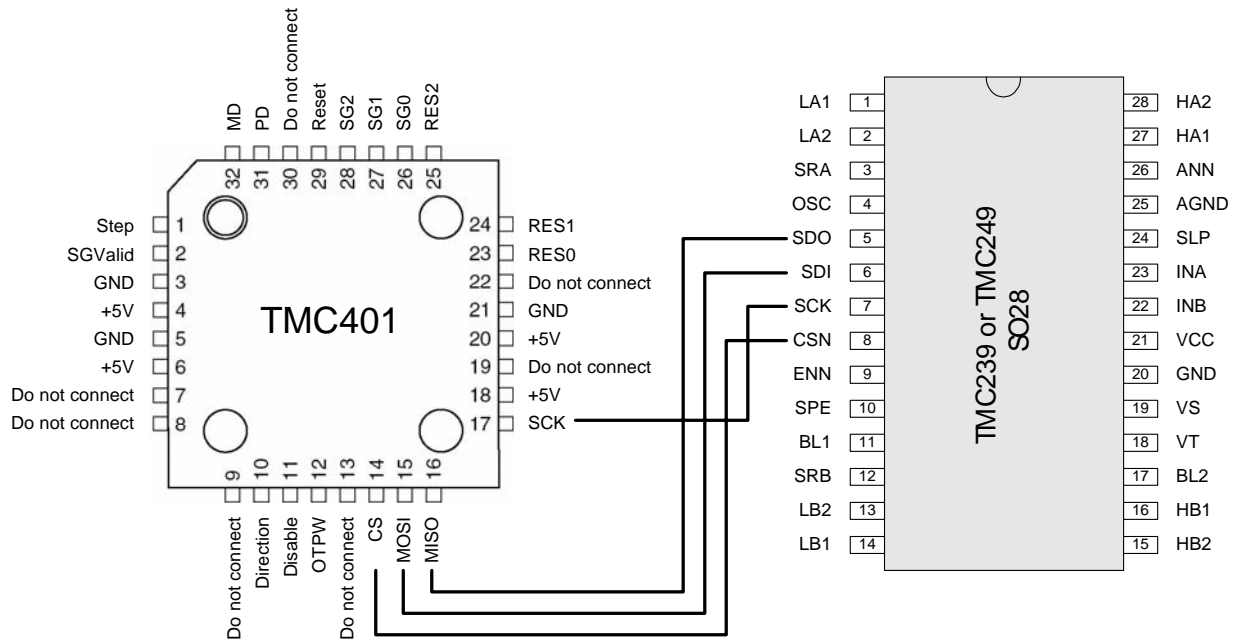

Figure 5.3: Application with a TMC239 or TMC249 driver with SPI

5.3 Inputs

The inputs are mainly for the control of the additional features of the TMC23x and TMC24x driver family and of course for the step- /direction signal.

5.3.1 Step- / Direction signal

Step-Direction signal timing:

	Min
T_{S2D}	2 μ s
T_{D2S}	0 μ s
th	0.125 μ s
f_{STEP}	245 kHz

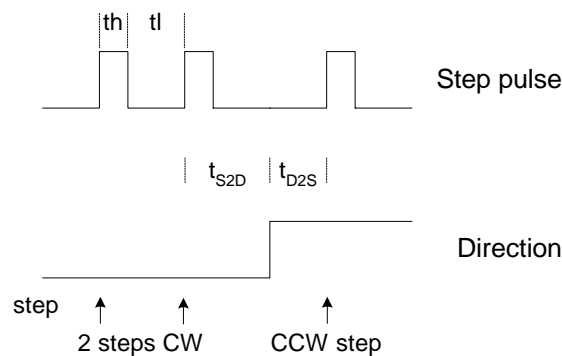

Figure 5.4: Step / Direction signal timing

5.3.2 Setting of microstep resolution

For the resolution of a motors rotation the microstep resolution has to be set. Thus each sent step impulse is interpreted accordingly.

RES ₂	RES ₁	RES ₀	Microstep resolution
0	0	0	1/32
0	0	1	1/16
0	1	0	1/8
0	1	1	1/4
1	0	0	1/2
1	0	1	1/1
1	1	0	Full step with matched current
1	1	1	Full step with full current

Table 5.1: Mircostep resolution setting

The resolution selection inputs have internal pull-up resistors.

5.3.3 Automatic Power down

The PD pin controls the automatic power down feature. If this pin is low the motor current will be lowered to approx. 25% of the actual current after there has been no step pulse for at least one second. The current will be raised to 100% again as soon as the next step pulse occurs.

When the PD pin is high (or open, as the PD pin has an internal pull-up resistor) the current will always stay at 100%.

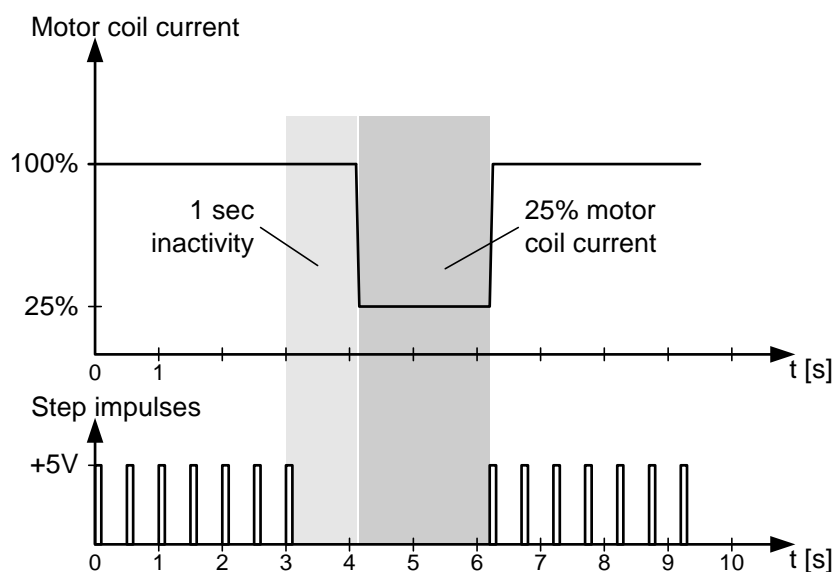

Figure 5.5: Power down feature

5.3.4 Mixed Decay

The MD pin controls the use of the Mixed Decay feature of the TMC249/TMC249. Mixed decay will be enabled when the MD pin is pulled low. It will be disabled when the MD pin is high or open (the MD pin has an internal pull-up resistor).

The mixed decay setting especially at rotation velocities in the range of a few 10 steps per seconds to several 100 steps per second improves motor behavior (less resonance). However, the actual performance depends on the motor and mechanics. For supply voltages above 24V and for low inductivity motors, best microstep behavior is reached when mixed decay setting is continuously on.

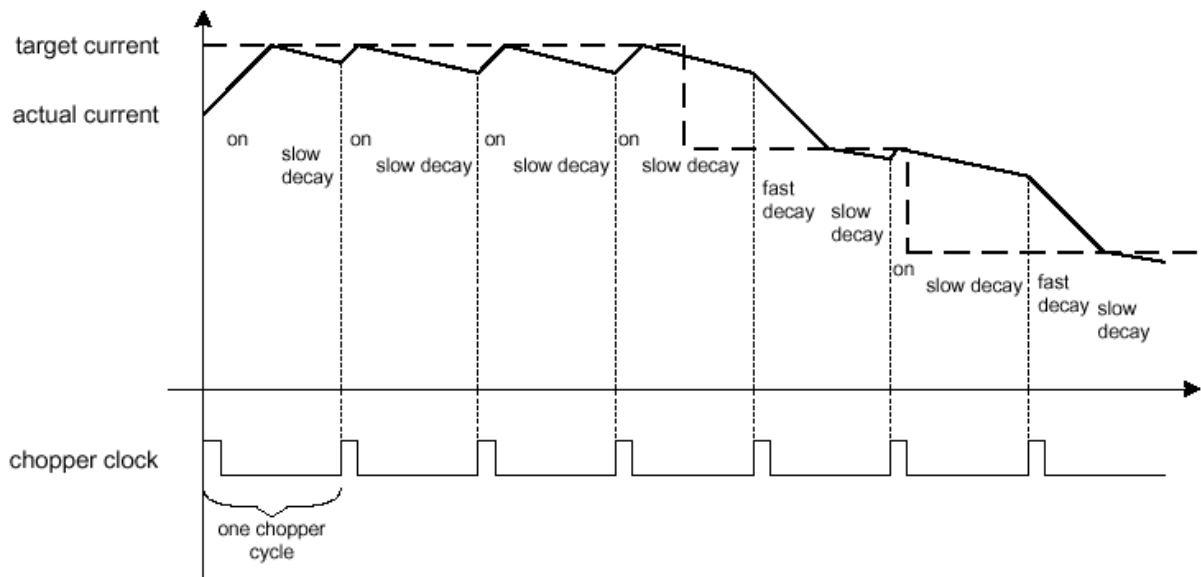

Figure 5.6: Different Chopper Cycles with Fast and Slow Decay

Figure 5.6 shows differences in chopper cycles with Fast and Slow Decay. Fast decay is better at high velocities, while slow decay shows better performances at low velocities. With the mixed decay feature activated the modes will be switched automatically for best motor performances. Mixed decay should be switched off in standstill to avoid possible chirping noise and when StallGuard operational in order to get usable results.

5.3.5 Disable

The disable pin (pin 11) can normally be left open or connected to +5V via a pull-up resistor. Pulling this pin low disables the SPI communication by tristating all 4 SPI pins.

5.3.6 Reset

The reset pin can normally be left open or connected to +5V via a pull-up resistor. Pulling this pin low resets the device, but this is normally not needed as the device is equipped with automatic power-on reset and brown-out protection.

5.4 Outputs

5.4.1 Overtemperature pre-warning

The OTPW pin is an output pin that shows the state of the OTPW bit of the TMC236/239/246/249. It is high when the OTPW bit is set (that means, there is an overtemperature pre-warning) or low when the OTPW bit is not set. The OTPW pin can be directly connected to the enable input of the TMC236/239/246/249 when the motor shall be switched off automatically if there is an overtemperature pre-warning.

The pre-warning temperature is min.: 135, typical: 145 and max.: 155 °C

5.4.2 StallGuard

The load detection bits LD2..LD0 of the TMC246/TMC249 are output to the StallGuard output pins SG2..SG0. Every time the StallGuard bits become valid a low pulse of approx. 4µs is generated on the SGValid output. At this times the StallGuard value can be read out. Please see [TMC246], [TMC249] for further information.

6 Package information

32 lead Thin Profile Plastic Quad Flat Package (TQFP) with 7 x 7 mm body size, 1.0mm body thickness and 0.8mm lead pitch.

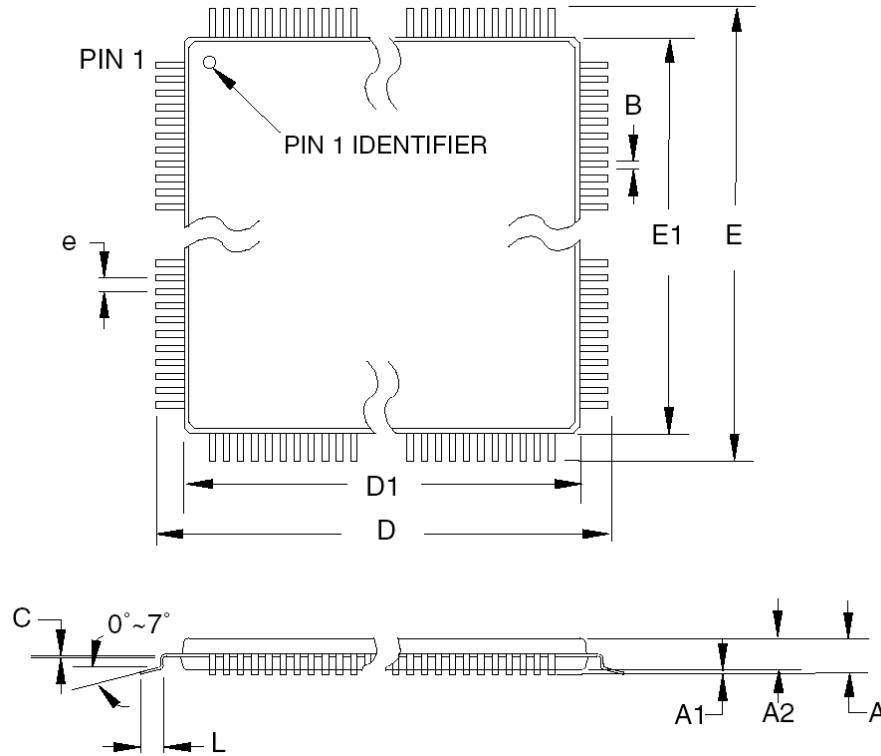

Figure 6.1: Package Outline

SYMBOL	MIN	NOM	MAX	UNIT
A	-	-	1.20	mm
A1	0.05	-	0.15	
A2	0.95	1.00	1.05	
D	8.75	9.00	9.25	
D1	6.90	7.00	7.10	
E	8.75	9.00	9.25	
E1	6.90	7.00	7.10	
B	0.30	-	0-45	
C	0.09	-	0.20	
L	0.45	-	0.75	
e	0.80 TYP			

Table 6.1: Package Dimensions

7 Documentation Revision

Version	Comment	Author	Description
1.0	16-Mar-2007	HC	Initial Version

8 References

- [TMC236] Microstep driver manual, 1.5A phase current (see <http://www.trinamic.com>)
[TMC246] Microstep driver manual, 1.5A with StallGuard (see <http://www.trinamic.com>)
[TMC239] Microstep driver manual, up to 4A phase current (see <http://www.trinamic.com>)
[TMC249] Microstep driver manual, up to 4A with StallGuard (see <http://www.trinamic.com>)